

RAIL TIE SPACING 24"

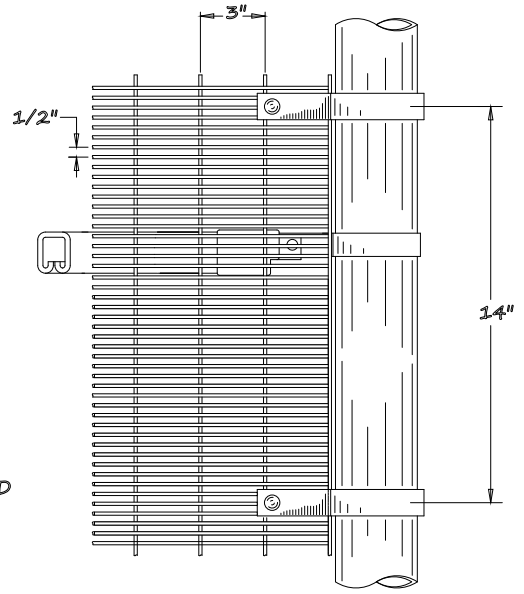

END/CORNER CONNECTION

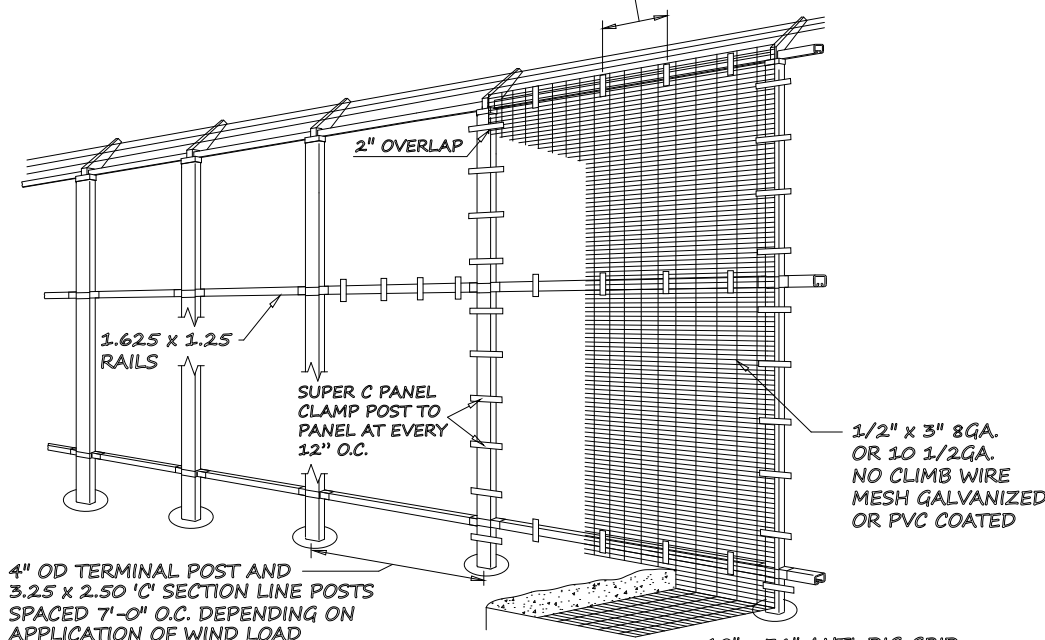
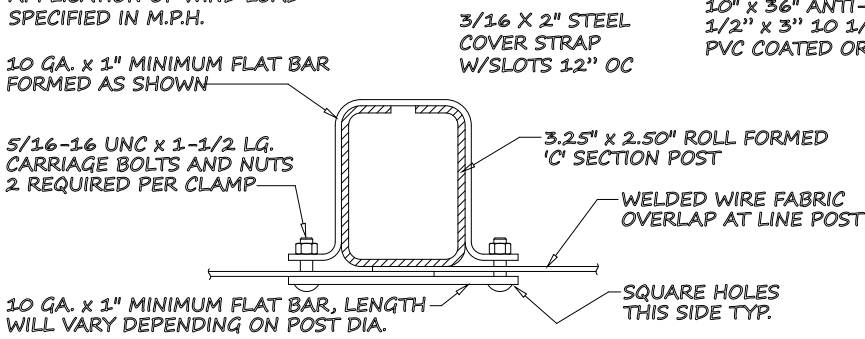

ITEM		QNTY	DESCRIPTION		MATERIAL
			MACHINING TOLERANCES		FABRICATION TOLERANCES
SCALE	NONE	CHK'D BY	DTM	0.1 ± 0.030	UNDER 18" ± 1/32
				0.02 ± 0.015	18" AND OVER ± 1/16
				± 0.005	ALL MACHINED SURFACES ± 1/16
				ANGLES ± 1/4#	BREAK ALL SHARP EDGES
DWN BY DTM 01-01-17 APP'D BY					
SUPER 'C' with BARB WIRE, ROUND TERM. PANEL CLAMPS (WELDED WIRE)					

CAD FILENAME:  
FENCE 4-12  
LAST PLOT DATE:  
09/01/17

**GREGORY**  
FENCE  
4100 13th Street SW  
Canton, Ohio 44710

REF. No.  
DRWG. No.  
FENCE 4-12